

Vulcan Primed Cladding

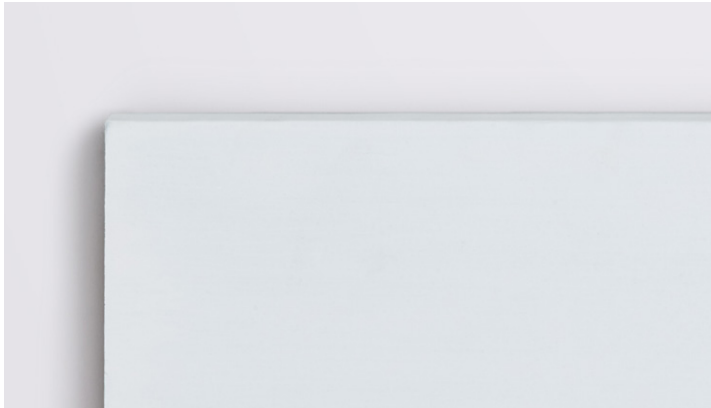

Overview

Vulcan Primed Cladding is created from thermally modified New Zealand plantation timber and factory pre-primed for optimal coating performance.

The thermal modification process means Vulcan Primed Cladding has enhanced stability, reduced resin content so is good for dark colours, and is naturally durable so does not require any added chemical preservatives.

When specified and installed in accordance with the manufacturers instructions Abodo Cladding systems will achieve CodeMark status for guaranteed acceptance with New Zealand building consent authorities.

Available in the innovative Hector secret fix system that means no punching and putting of face fixings is required, so can you benefit from big reductions in installation time and superior performance in service.

Wood species: Thermally Modified Radiata Pine (Pinus Radiata).

Standard profiles:



WB10P 135x18
(115mm cover) Stocked profile.
Order subject to minimum order quantity and lead time.



WB10P 180x18
(160mm cover) Stocked profile.
Order subject to minimum order quantity and lead time.



WB10FP 180x18
(160mm cover) Supplied as a custom profile.
Order subject to minimum order quantity and lead time.

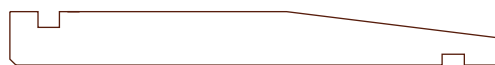

AW62P 187x18
(155mm cover) Supplied as a custom profile.
Order subject to minimum order quantity and lead time.

Lengths: Fixed length 6.1m, up to 10% of an order may be supplied mixed length 1.2m and longer.

Vulcan Primed Cladding

Product specifications

Name:	Abodo Vulcan Primed Cladding.
Quality:	Select Grade /Front face and edges virtually free of any defects but with one edge knot and one small face defect allowed per piece in 20% of boards only. Back side with some defects allowed according to Feature grade including machine defects.
Substrate colour :	Chocolate brown timber with light blue or white coloured factory primer coating.
Finish:	Smooth dressed face.
Durability:	Thermally modified – INTENZ Thermowood 230 degrees schedule. No chemical preservatives used. Field tested at SCION, Rotorua. Approved for uses described in NZS3602:2003 Table 2A 'Requirements for wood-based building to achieve a 15 year durability performance Members exposed to exterior weather conditions and dampness'. Durability Class 1 (EN350-1), Class 2 above ground (AS5604). Available optionally treated for termite-prone areas.
Moisture content:	Approx. 7% MC (+/-2%) at time of dispatch.
Construction:	Solid timber or finger jointed with Type 1 polyurethane adhesive (VOC and formaldehyde free).
Intended use:	Intended for use in residential and light commercial buildings with risk score of 20 or below as per 'Weather rightness risk matrix' in E2/AS1.
Minimum life :	15 years as required by NZS3602.
Serviceable life:	30 years or more when maintained according to manufacturers recommendations.
Warranty:	15 years against fungal attack (subject to terms and conditions).
Coating:	Supplied with two factory coats of Resene Truprime primer/undercoat. Vulcan Primed must have two coats of quality acrylic exterior house paint applied within 60 days of installation. Where dark colours are to be used it is recommended to use Resene CoolColour™.
Expected dimensional thickness change in structure:	Tangential/Width expansion from dry approx 3.0%, length expansion approx 0.25%, radial/ expansion approx 1.5% (variation may occur between boards).
Average density:	420 kg/m ³ .
Hardness:	Low (2.5kN Janka).
Weight:	~11 kg/m ² ('light weight cladding' NZS3604).
Thermal properties:	-0.11 W/(mK).
Compatibility:	Vulcan has little or no corrosiveness on metals (separation from zinc is required) and can be placed in contact with most building materials Normal PVA, PU, MUF glues and RF resins can be used.
Certification:	FSC®-certified mixed, No.: SGS-COC-004944.
NZBC compliance:	CodeMark Certified cladding system- certificate number CMA-CM40070.

Product handling

- Weatherboards and accessories must be kept clean dry, under cover and out of the weather prior to installation.
- Product must be stored horizontally on bearers at least 100mm off the ground.
- Extra care must be taken during installation so as not to damage the factory finish of the boards.
- Wear dust mask, eye protection when cutting timber.
- Do not burn treated timber. Dispose of off-cuts in lined land fill or an approved furnace.

Vulcan Primed Cladding

Fixing overview

- Timber framing is to be in accordance with NZS3604. Studs must be spaced at max 600mm centres. If installing horizontal weatherboards nogs must be spaced at max 800mm centres. If installing vertical weatherboards nogs must be spaced at max 480mm centres, or max 800mm centres if using structurally fixed CBH-45x45mm cavity battens.
- Fix cladding over a water proof, breathable building wrap, rigid air barrier or other suitable waterproof substrate in conformance with NZBC E2/AS1.
- Base of cladding must not sit directly into flashings or other cladding materials such as masonry. Minimum 5mm gap must be left to flashings allowing fall to shed water away from the wall cavity.
- Use of a cavity system is recommended with minimum 45x18mm H3.1 battens (a cavity is required for CodeMark certification).
- For vertical fix weatherboards, horizontal cavity battens should be castellated (notched) eg: CBH-20x45, CBH-45x45 and bevelled to allow water run off in service.
- Structurally fixed timber cavity battens are allowed, provided battens are fixed with stainless steel flat head nails or 10g screws staggered at min 300mm centres when using a 20x45mm cavity batten or 600mm centres when using a 45x45mm cavity batten and with min 40mm fixing penetration into stud.
- Fix boards either vertically or horizontally as appropriate to the profile type specified at the following maximum batten spacings:
 - 480mm centres for vertically fixed weatherboards (WB10); or
 - 600mm centres for horizontally fixed weatherboards (Bevelback, WB10)
- High quality hot dip galvanised fixings should be used as minimum. Stainless steel fixings should be used in areas near the sea. Pre-drill fixings using a drill bit 1/3rd smaller than the fixing.
- For **Bevelback, Vertical shiplap and Rusticated weatherboards**, use jolt head nails (hand driven) to achieve minimum 35mm penetration into stud (or stud and batten combined if using a structurally fixed cavity batten) and positioned approximately 10mm beyond the over- lap. Punch, putty, spot sand and prime fixings immediately and prior to painting.
- For **WB10 secret fix profile**, use flat head ring shank nails or 6g counter sunk head screws so as to achieve 30mm penetration into stud (or stud and batten combined if using a structurally fixed cavity batten) and positioned into the fixing positioning groove 12mm from the tongue edge. Fixing with self drilling/ counter sinking screws is recommended. Punching/puttying of fixings is not required apart from where fixings are through face of boards.
- Fixings at ends of boards must be at least 12mm from edge, and must be pre-drilled before applying fastener. Ensure 2mm expansion gap to back of boards.
- Cut ends and notches must be sealed with primer/undercoat, prior to application of top coats.
- Joins between board ends must be made over battens only, using a 35degree mitre, and application of sealant at the join eg: Sikaflex 11FC.
- Use Abodo finishing mouldings or soakers backed by hemmed corrosion resistant internal flashings as required, windows, doors and where cladding meets soffit in accordance with E2/ AS1. Fix mouldings with jolt head nail (hand driven) at max 450mm centres- punch, putty and prime as required. Check Abodo drawings for detail.
- For cavity systems, use perforated cavity base closer flashing at base board to allow drainage, air flow and keep out vermin. For Hector horizontal weatherboards, use the AWF1 Abodo WB10 closer.
- Ensure boards are dry and at equilibrium moisture content or no greater than 16%MC prior to applying top coats.
- Some cracks or minor defects may be present as part of the natural acclimatisation of the timber. These can be repaired using exterior grade filler. Spot sand and prime these areas prior to painting. Within 60 days of installation, apply two coats of quality acrylic house paint in accordance with AS/NZS2311.
- Where dark colours are to be used it is recommended to use Resene CoolColour and apply first top coat to the over lap area prior to fixing to avoid possibility of exposed shrinkage lines in service. Refer to Resene Coatings Specification M20-09-14 for full specification details.

Vulcan Primed Cladding

Fixing details:

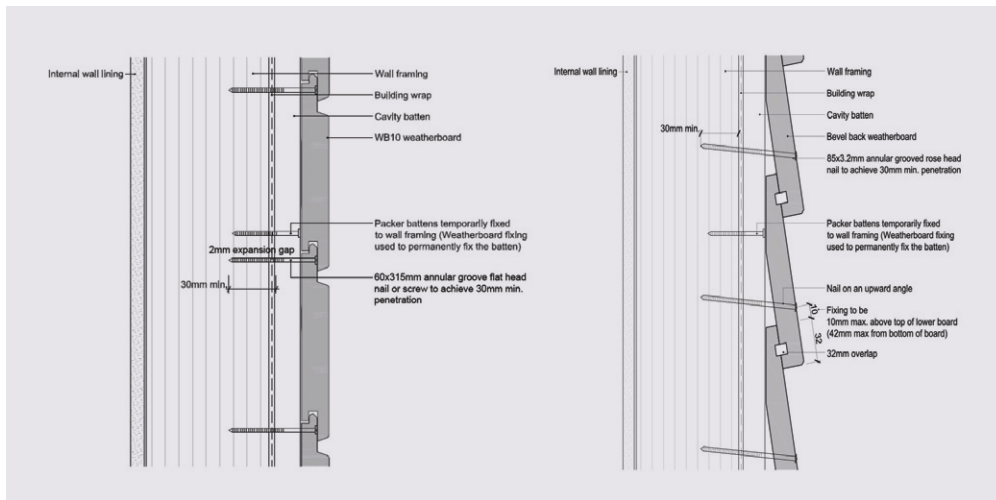

Fig 1 – WB10 Secret Fix

Fig 2 – Bevel Back Face Fix

Note: The adjacent is an overview only.
Please refer to CodeMark Weatherboard Cladding Manual CWB-M-130925 and detail drawings at: abodo.co.nz/product for detailed installation information prior to specification or commencement of construction.

Maintenance

- Wash down every 12 months with gentle detergent, warm water and soft brush.
- Make a maintenance check every 2 summers. Check all weatherboards, junctions, flashings, mouldings and replace or remediate as required to maintain weather tightness of the cladding system.
- Re-coat approximately every 8-10 years or as per coating manufacturer’s specification.

Surface checking:

- Checking (cracks) may be observed on the face and ends of Vulcan timber. Checking may become more apparent as the material weathers naturally in place. These are not defects and are considered a natural part of this wood product. Cracks can be repaired using exterior grade filler. Sand and prime the affected area prior to application of top coat. Maintenance with a coating and thorough sealing of end grains with paint will improve long term weathering characteristics.

Abodo flashings

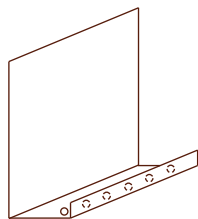

AWF1 Abodo Hector Horizontal Base Cavity Closer S/Steel 3m (for use with WB10 horizontal profile only)

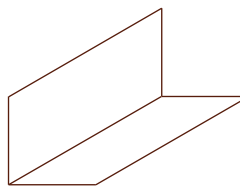

AWF2 Abodo Unhemmed Corner Flashings S/Steel 100x100 mm/120x120mm 3m

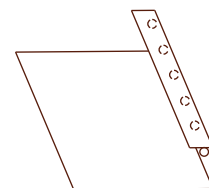

AWF3 Abodo Window Jamb Flashing S/Steel 3m (for use with WB10 horizontal profile only)

Vulcan Primed Cladding

Exterior mouldings:

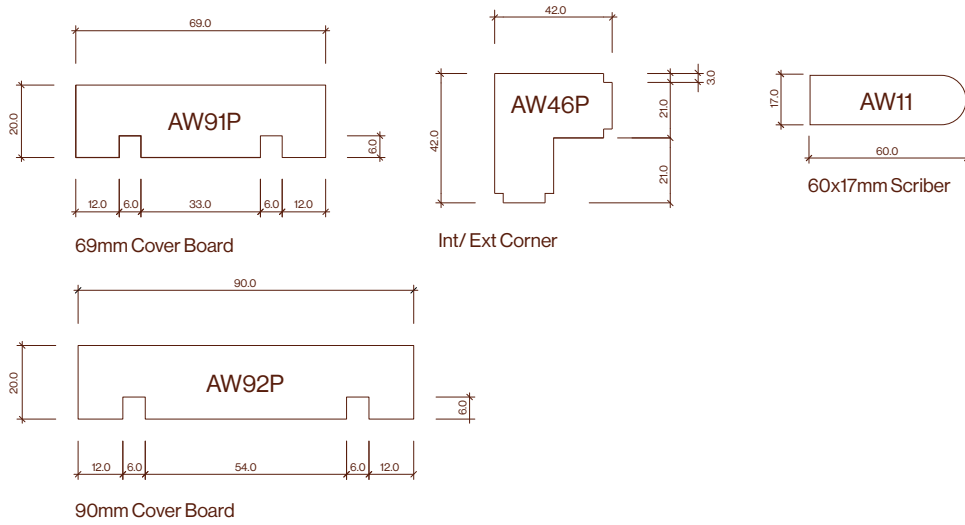

Horizontal castellated cavity battens:

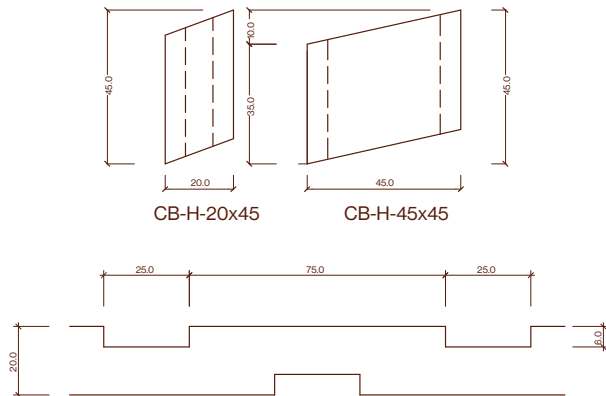

Note: Other profiles are available and should be specified according to the system being used- please refer to Abodo Cladding Architectural Profile Chart and CodeMark Weatherboard Cladding Manual CWB-M-130925 for more details.

Accessories

Abodo Stainless Steel Cladding Screw 4.0mm x 45mm or 4.5mm x 65mm:



P +64 9 249 0100
E info@abodo.co.nz
W abodo.co.nz